

Installation instructions 1.2PD/ 1.4PD

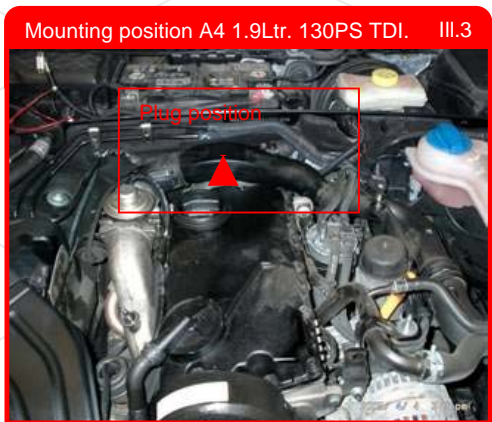
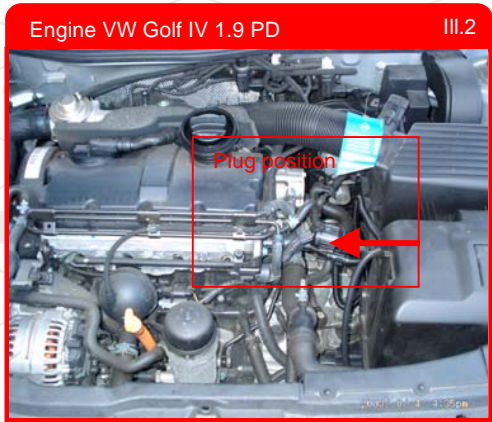
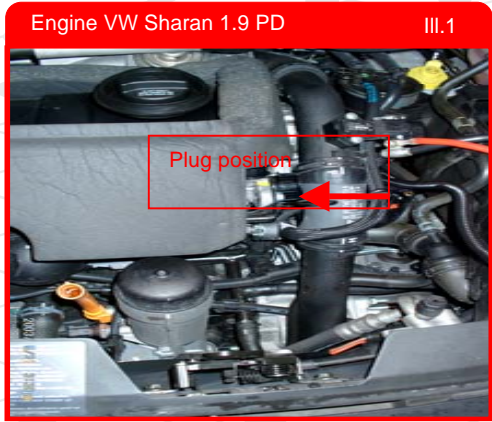

Installation 1.2PD/ 1.4PD

- Switch the ignition off.
- Remove the engine cover.
- **Adapter assembly**
Localise the both round plugs and connect them until they click in. The original plug connection is at lengthways built-in engines at the end of the cylinder head, near the splashing wall. At crossway built-in engines it is at the left side. To unlock the connection you have to pull off the red pin.
- Connect the round adapter plug between the cylinder head (Pumpe/Düse element) and the motor control unit. Pay attention for a correct connection!
- **Power supply**
Connect the red cable with the plus pole of the battery.
Connect the black cable with the minus pole of the battery.
- Connect the wiring loom with the PD-modul.
Your car is now ready for a test drive.

- **Performance adjustment:**
Open the modul at the back.
Jumper position to the left side: the performance decreases
Jumper position th the right side: the performance increases

- **Installation position**
With crosswise built-in engines the position is at the right side.

III.1 Example VW Sharan 1.9 Ltr. 130bhp TDI
III.2 Example VW Golf IV 1.9 Ltr. 101bhpTDI

Einbaulage
With lengthwise built-in engines the position is at the right side.

- III.3: Example A4 1.9 Ltr. 130bhp TDI.

- **Attention!**
If your car should not run with the system, you must remove the complete system.
If you don't remove the wiring loom, your car will not start.

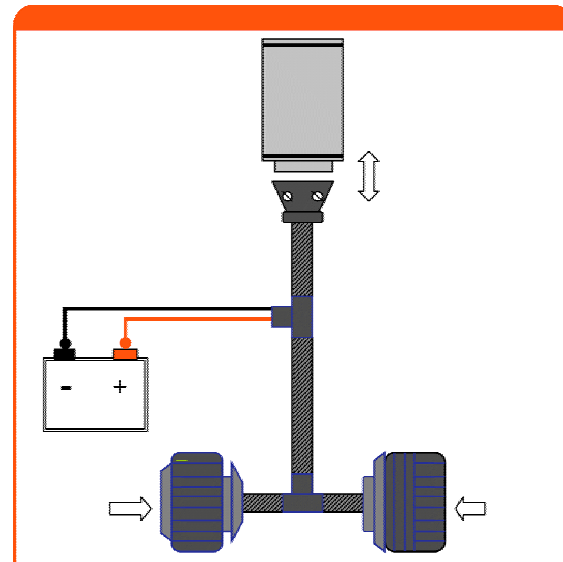

Explanation LED view	LED green	LED red
Operable (Engine off)	on	off
Operable (Engine on)	blinking	off
Tuning activated	blinking	on

